

RANGE
2WD
2 WHEEL DRIVE



 **ST82-14**
TRANSVERSE

SADEV
RACING TRANSMISSION

SADEV[®]
RACING TRANSMISSION

RANGE
2WD
2 WHEEL DRIVE



ST82-14 TRANSVERSE

The bestseller in the transverse range, the **ST82-14** is loaded with the latest technology. Designed for turbocharged engines such as 1.6L turbo and benefiting from all SADEV's experience, it combines optimised architecture with a small footprint and a low weight. Incorporating all the latest innovations such as paddle-shift, the **ST82-14** will prove a formidable solution for your future projects.

APPLICATIONS

- › Circuit
- › Hill Climb
- › Rallycross
- › Rally



TECHNICAL SPECS

6 speed sequential gearbox + 1 reverse gear

Manual sequential gear selection (semi-auto optional)

Wide range of final drives available

Wide range of ratios available

Straight cut gears

Dog ring gear engagement

Interchangeable gear ratios

High strength carburizing steel

Gear teeth grinded with optimized profile

Shot penning on internal parts

Specific input shaft

Central limited slip differential

Ramp and plate system - 3 discs type

Preload made by spring washer

Wide range of ramp plates available

Reverse lockout cable (solenoid system optional)

Contactless gear position sensor

Contactless flat shift sensor

Splash lubrication system

Oil pump integrated (optional)

Oil suction screen

Magnetic drain plugs

Painted AS7G aluminum casings

Case joint faces sealed with O'rings

Weight (input shaft included) : 35 Kg - 77 lbs

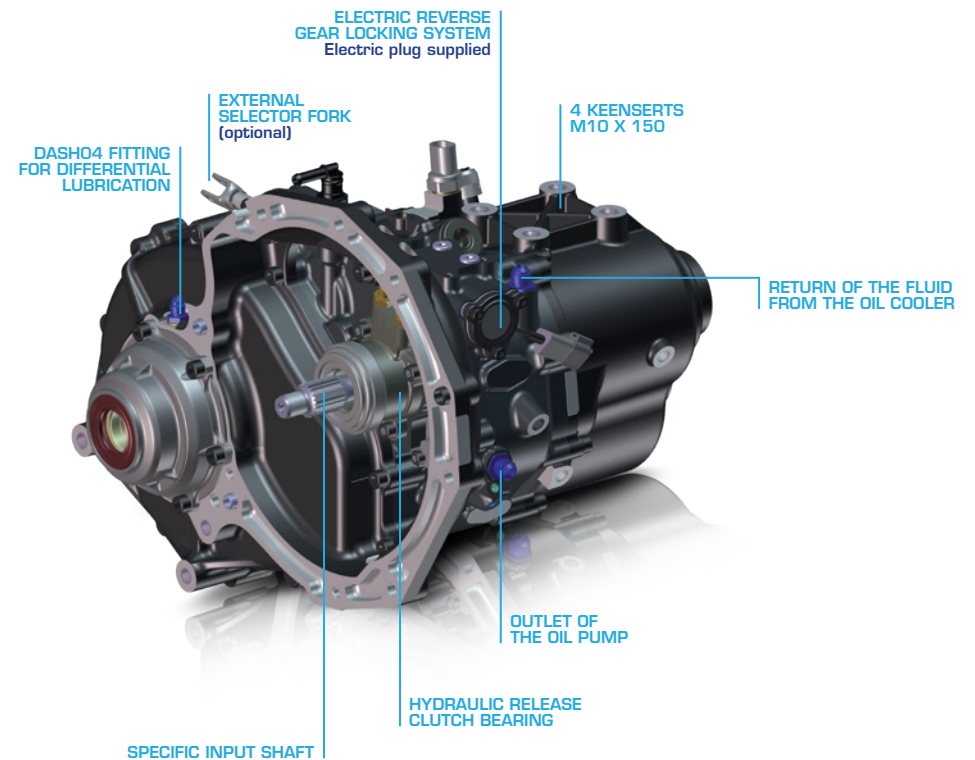
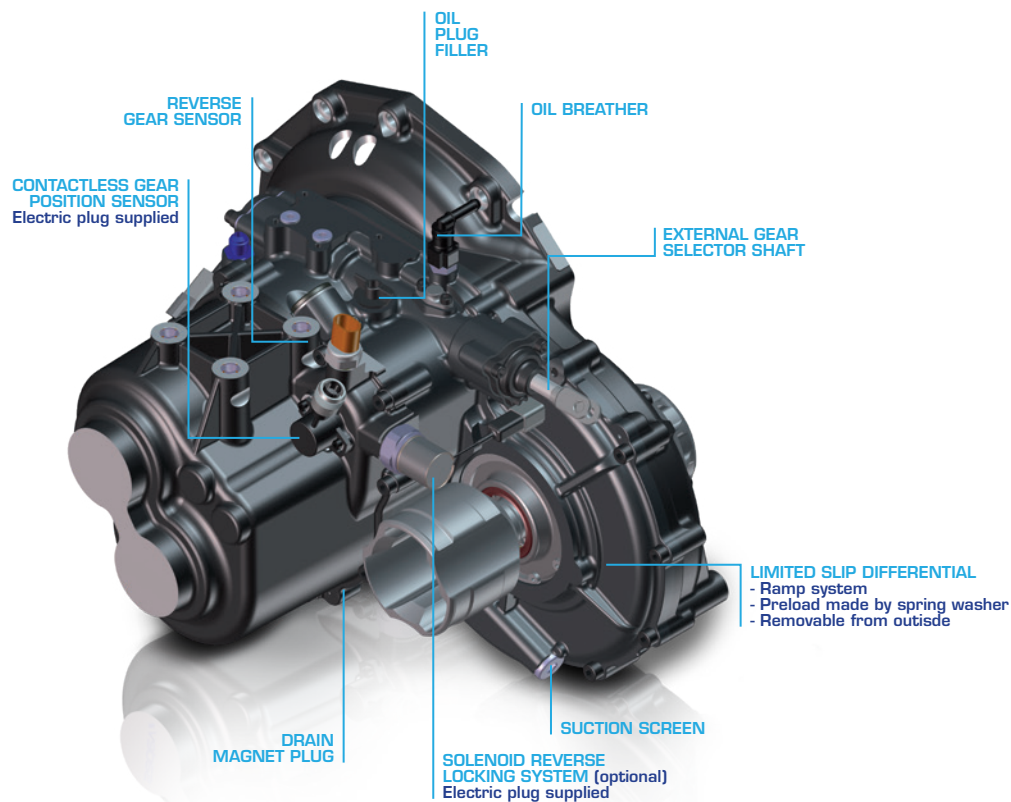

ACCESSORIES

- › Gear display
- › Driven tripod flange
- › Mounting plate
- › Gearlever
- › Hydraulic paddle-shift
- › Drive shafts

LIMITED SLIP DIFFERENTIAL

Self-locking ramp differential accessible from the outside

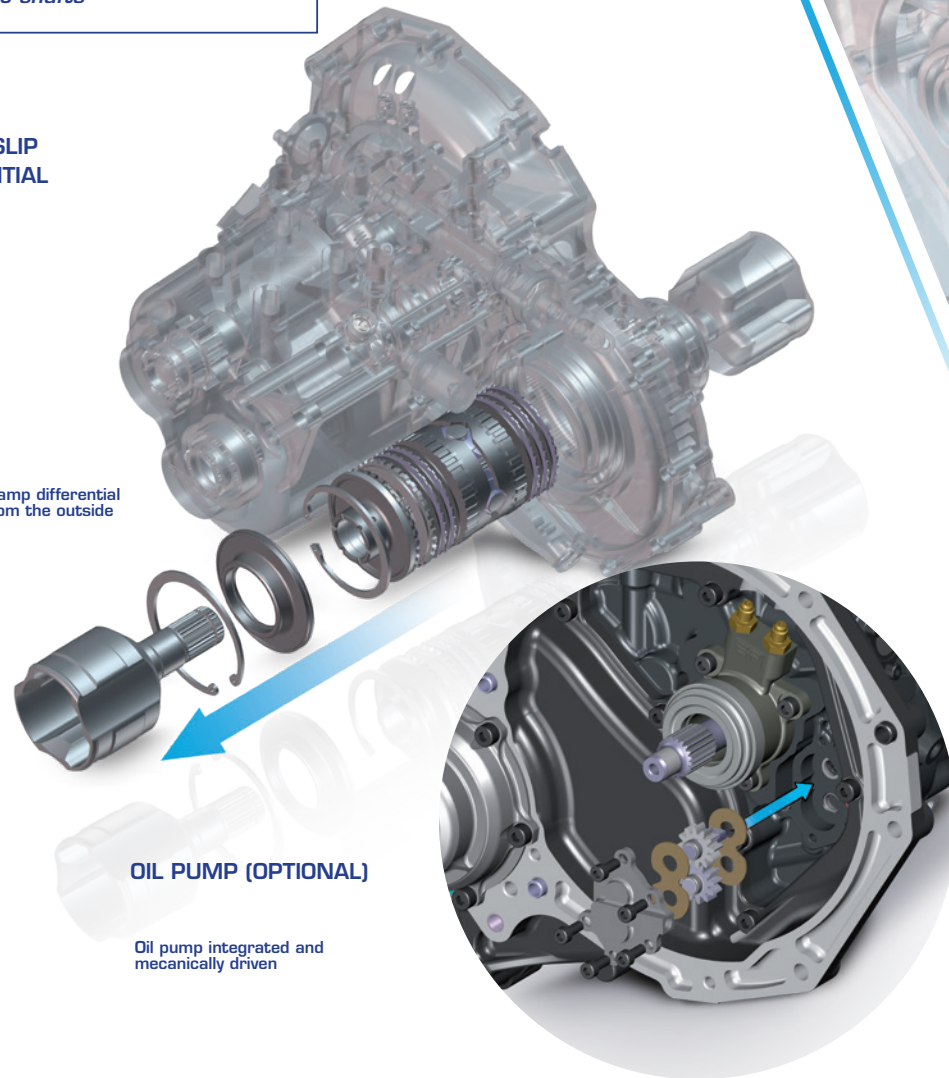

OIL PUMP (OPTIONAL)

Oil pump integrated and mechanically driven

HYDRAULIC PADDLE-SHIFT (OPTIONAL)

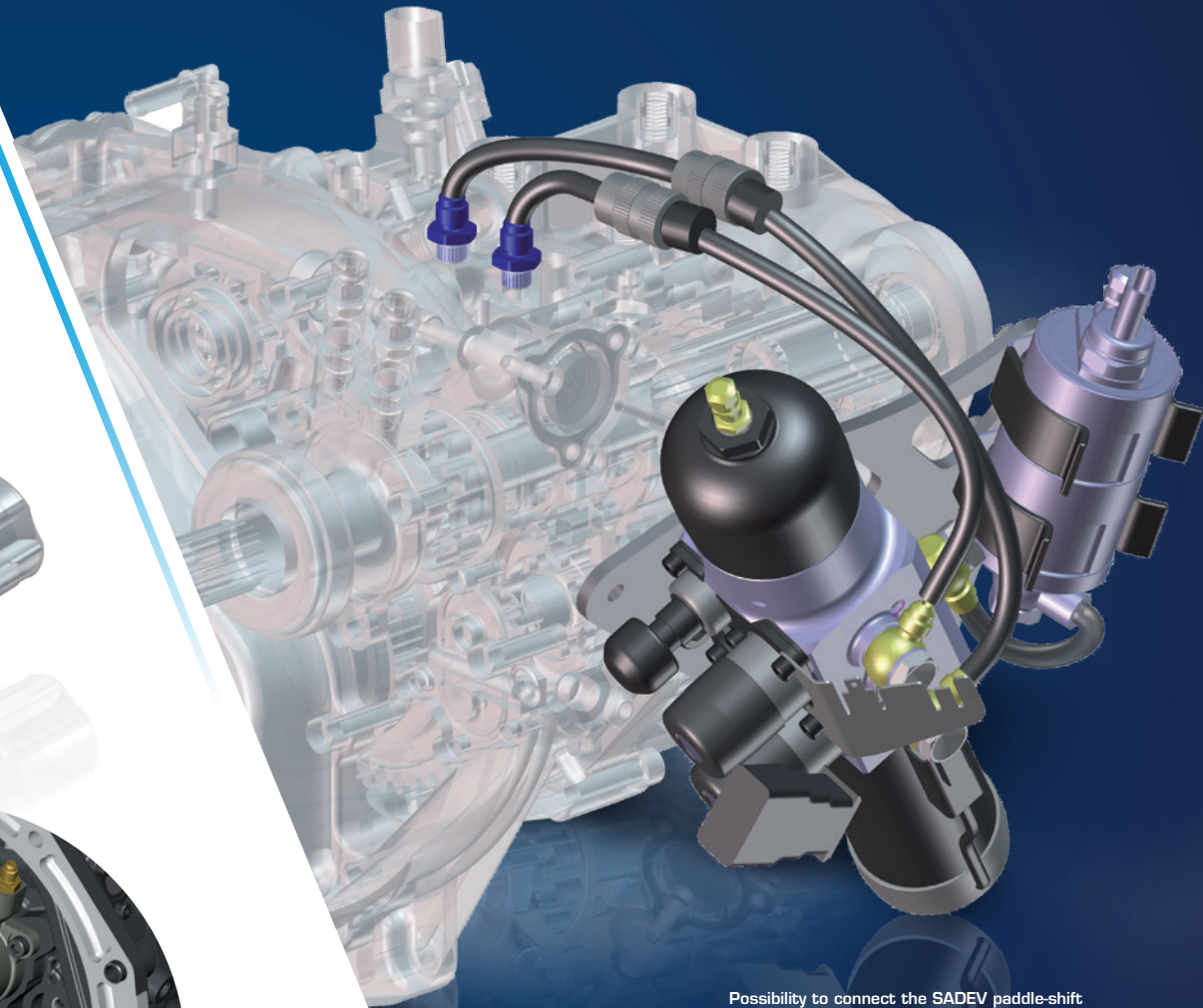

Possibility to connect the SADEV paddle-shift system and to operate the transmission via an integrated actuator.



ST82-14 TRANSVERSE

- › **Selection:** An internal actuator can be fitted to the **ST82-14** to receive the SADEV paddle-shift system.
- › **Ratio selection:** Optimised clutch and control shaft definition for smoother gear shifting.
- › **Architecture:** The offset geartrains mean the engine and gearbox can be positioned as low as possible.
- › **Dimensions:** The reduced size of the **ST82-14** means it fits into most 2-wheel-drive vehicles.
- › **Robustness:** Our finite element calculation tool enables us to design extremely strong, compact, lightweight casings.
- › **Cooling:** An oil pump can be integrated into the **ST82-14**. Driven mechanically, this enables an external oil cooler to be connected.

MAXIMUM ENGINE TORQUE

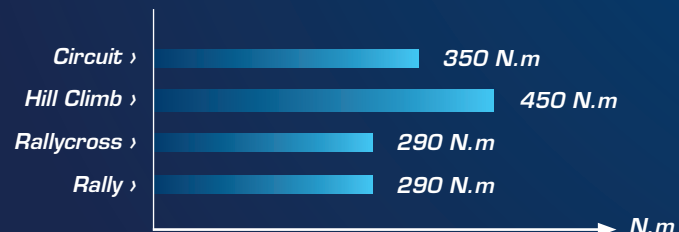



ONE PASSION: VICTORY

SADEV has an exceptional record in supplying unique engineering to the most prestigious drivers and manufacturers. SADEV's products stand out for their technology, their excellence and their ambition. As precise as they are reliable, these high-tech masterpieces are the key to your victory. SADEV has just one goal: to make sure you win.

FOLLOW US



WWW.SADEV-TM.COM

6, rue Grand'Montains - 85110 SAINT-PROUANT - FRANCE

Tel: +33 (0)2 51 66 42 68

sadev@sadev-tm.com



A TEAM AT YOUR SIDE

FRANCE	SADEV FRANCE - sadev@sadev-tm.com
USA	SADEV TRANSMISSIONS, INC. - info.usa@sadev-tm.com
UK	SWR MOTORSPORT LTD - serviceswrmotorsport@gmail.com
ITALY	GIEFFE RACING - info@giefferacing.com
SPAIN	DE LA PUENTE MOTORSPORT - dlpmotorsport@movistar.es
NETHERLANDS	RACING DEVELOPMENT - info@racingdevelopment.nl
NETHERLANDS	PETERS AUTOSPORT - bart@petersautosport.nl
BELGIUM	R TEC - info@rtec.ws
CZECH REPUBLIC	SADAC - info@sadac.cz
GERMANY	MTO ENGINEERING - info@mtoengineering.com
SWEDEN	HANSEN MOTORSPORT - kenneth@hansen-motorsport.se
DENMARK	GUNNAR AASKOV MOTORSPORT - mail@aaaskov-motorsport.dk
FINLAND	SET PROMOTION - kalle.pinomaki@setpromotion.com
SWITZERLAND	CHRISTIAN FERRARI - ferrach@bluewin.ch
SOUTH AFRICA	CENTURY RACING - julien@centuryracing.co.za
ARGENTINA	JPO RACING - racingjpo@gmail.com
BRAZIL	CD MOTORSPORT ENGINEERING - sadev.brasil@gmail.com

